



# **MARKSCHEME**

**November 2013**

**BUSINESS AND MANAGEMENT**

**Higher Level**

**Paper 2**

29 pages

*This markscheme is **confidential** and for the exclusive use of examiners in this examination session.*

*It is the property of the International Baccalaureate and must **not** be reproduced or distributed to any other person without the authorization of the IB Assessment Centre.*

The markbands on pages 3–4 should be used where indicated in the markscheme.

Section A		Section B			Level descriptors
Q1 (d)	Q2 (d)	Q3 (c)	Q4 (c)	Q5 (d)	
Marks 0–6					
0					<ul style="list-style-type: none"> <li>• No knowledge or understanding of relevant issues, concepts and theories.</li> <li>• No use of appropriate terminology.</li> </ul>
1–2					<ul style="list-style-type: none"> <li>• Little knowledge and understanding of relevant issues, concepts and theories.</li> <li>• Little use of appropriate terminology.</li> <li>• No reference is made to the information in the stimulus material. The response is mainly theoretical.</li> </ul>
3–4					<ul style="list-style-type: none"> <li>• A description or partial analysis/examination with relevant knowledge and/or understanding of relevant issues, concepts and theories.</li> <li>• Some use of appropriate terminology.</li> <li>• Some reference is made to the information in the stimulus material, not just to the name of the organization.</li> </ul>
5–6					<ul style="list-style-type: none"> <li>• A balanced analysis/examination with accurate, specific, well-detailed knowledge and understanding of relevant issues, concepts and theories.</li> <li>• An analysis/examination that uses appropriate terminology throughout the response.</li> <li>• Explicit references are made to the information in the stimulus material.</li> </ul>

<b>Section B</b>			<b>Level descriptors</b>
<b>(d) questions</b>			
<b>Q3 (d)</b>	<b>Q4 (d)</b>	<b>Q5 (e)</b>	
<b>Marks 0–9</b>			
<b>0</b>			
<b>1–2</b>			<ul style="list-style-type: none"> <li>• Little knowledge and understanding of relevant issues, concepts and theories.</li> <li>• Little use of appropriate terminology.</li> <li>• No evidence of judgments and/or conclusions.</li> <li>• No reference is made to the information in the stimulus material.</li> </ul>
<b>3–4</b>			<ul style="list-style-type: none"> <li>• A description with some knowledge and/or understanding of relevant issues, concepts and theories.</li> <li>• Some use of appropriate terminology.</li> <li>• No evidence of judgments and/or conclusions.</li> <li>• Some reference is made to the information in the stimulus material, not just to the name of the organization.</li> <li>• The response is mainly theoretical.</li> </ul>
<b>5–7</b>			<ul style="list-style-type: none"> <li>• A response with relevant knowledge and understanding of relevant issues, concepts and theories.</li> <li>• A response that uses relevant and appropriate terminology.</li> <li>• Evidence of judgments and/or conclusions that are little more than unsubstantiated statements that has balanced analysis and demonstrates understanding.</li> <li>• Explicit references to the information in the stimulus material are made at places in the response.</li> </ul>
<b>8–9</b>			<ul style="list-style-type: none"> <li>• A response with accurate, specific, well-detailed knowledge and understanding of relevant issues, concepts and theories.</li> <li>• A response that uses appropriate terminology competently throughout the response.</li> <li>• A response that includes judgments and/or conclusions that is well supported and underpinned by a balanced analysis.</li> <li>• Explicit references to the information in the stimulus material are made throughout the response.</li> </ul>

**SECTION A**

**1. (a) Describe *one* advantage and *one* disadvantage of a private limited company. [4 marks]**

The advantages of a private limited company may include the following:

- the owners have a limited liability
- control of the company cannot be lost to outsiders without the agreement of current shareholders
- there may be some tax advantages
- more capital can be raised compared with a sole trader, or a partnership.

The disadvantages of a private limited company may include the following:

- the legal requirement takes time and costs money
- members of the public have access to financial information
- dividends should be given to shareholders which may reduce the retained profit.

*Accept any other relevant advantage/disadvantage with a description.*

**N.B.** Given that the question does not ask for application to *SF*, do not penalize candidates who do not refer to *SF*.

**Mark as 2 + 2.**

Award **[1 mark]** for each relevant and correct advantage/disadvantage of a private limited company identified and **[1 mark]** for an appropriate description up to a maximum of **[2 marks]**.

- (b) Explain *two* appropriate sources of finance that *SF* could use to purchase the 20 new scooters. [4 marks]

Appropriate sources of finance that *SF* could use to purchase the new scooters may include the following:

- given the large amount of funds required (\$80000) and the relatively medium-term life span of the fixed assets, *SF*'s Finance Manager may consider issuing more shares privately. A relatively large amount, or at least the required amount, of funds can be raised without interest payment, provided that the other shareholders agree.
- a bank loan can also be an option. The bank manager is likely to agree to the request as no information is given on any liquidity problem and it appears that *SF* is profitable and the current ownership will not be diluted and will stay within the family.
- hire purchase can be used which allows *SF*'s manager to not need to pay immediately for the scooters. This can be used to avoid depreciation.
- retained profit can also be used. It is said that the shareholders want more dividends so the assumption is that *SF* has been profitable. This option is an internal source of finance.
- through a leasing system *SF* will have the required fixed asset and will be able to use the scooters for a specific period of time without the responsibility of owning them. However, leasing, strictly speaking, is not purchasing. *SF* will have to make monthly leasing payments and at the end of the leasing period *SF* could decide to purchase the scooters. An initial deposit is not required.

*Accept any other relevant source of finance with an explanation.*

**N.B.** Although scooters are medium-term assets, do not penalise for a long-term source of finance. Do not accept short-term source of finance.

**Mark as 2 + 2.**

Award [1 mark] for each relevant and correct source of finance identified and [1 mark] for a relevant and correct explanation with application to *SF* or to its product (scooters) up to a maximum of [2 marks].

**N.B.** Just mentioning the name of the organization cannot be considered as application.

If there is no relevant application to the stimulus material award up to a maximum of [2 marks].

- (c) (i) Using the *straight line* method of depreciation, calculate the depreciation for each year *and* the book value (value of scooters less depreciation) of the 20 new scooters at the end of each year of their expected useful life (four years) (*show all your working*). **[4 marks]**

Using the straight line depreciation method the same value of depreciation is used every year  $\frac{\$80\,000 - \$4\,000}{4} = \frac{\$76\,000}{4} = \$19\,000$  per year.

Year	Depreciation in \$	Book value (fixed assets less depreciation) in \$
1 (2014)	19000	80000 - 19000 = 61000
2 (2015)	19000	61000 - 19000 = 42000
3 (2016)	19000	42000 - 19000 = 23000
4 (2017)	19000	23000 - 19000 = 4000

**[1 to 2 marks]**

The answers are largely inaccurate. The candidate shows only a superficial understanding of the notion of a straight line method of depreciation for **[1 mark]**. Award **[2 marks]** if there are two mistakes and/or the workings are not shown.

**[3 to 4 marks]**

Allow for up to one mistake for **[3 marks]** where the workings are fully shown and/or a table is well presented. For a correct answer which shows full working of the depreciation and end-of-year book value of the scooters for each of the four years, award **[4 marks]**.

Apply Own Figure Rule (OFR).

**N.B.** Do not penalize the absence of units (BOD).

- (ii) Using the *reducing balance* method of depreciation, calculate the depreciation for each year *and* the book value (value of scooters less depreciation) of the 20 new scooters at the end of each year of their expected useful life (four years). Use a 40% depreciation rate (*show all your working*). *[4 marks]*

Using the reducing balance method, assets are depreciated by a fixed percentage of 40% each year.

Year	Depreciation in \$	Book value (net fixed assets less depreciation) in \$
1 (2014)	$80\,000 \times \frac{40}{100} = 32\,000$	$80\,000 - 32\,000 = 48\,000$
2 (2015)	$48\,000 \times \frac{40}{100} = 19\,200$	$48\,000 - 19\,200 = 28\,800$
3 (2016)	$28\,800 \times \frac{40}{100} = 11\,520$	$28\,800 - 11\,520 = 17\,280$
4 (2017)	$17\,280 \times \frac{40}{100} = 6\,912$	$17\,280 - 6\,912 = 10\,368$

*[1 to 2 marks]*

The answers are largely inaccurate. The candidate shows only a superficial understanding of the notion of the reducing balance method for *[1 mark]*. Award *[2 marks]* if there are two mistakes and/or the workings are not shown.

*[3 to 4 marks]*

Allow for up to one mistake for *[3 marks]* where the workings are fully shown and/or a table is well presented. For a correct answer which shows full working of the depreciation and end-of-year book value of the scooters, for each of the four years, award *[4 marks]*.

Apply Own Figure Rule (OFR).

*N.B.* Do not penalize the absence of units (BOD).



- (iii) Explain *one* consequence of the Finance Manager's decision regarding the percentage rate at which the assets should be depreciated. **[3 marks]**

The depreciation rate should really be as accurate and realistic as possible.

A lower depreciation rate than the chosen 40% will result in a lower depreciation amount for each year, including 2014 and hence a lower depreciation amount under expenses in the profit and loss account; and hence creates a higher level of net profit before interest and tax. *SF* will have to pay a higher level of tax and will be left with less profit to be distributed as dividends.

Also, a lower depreciation amount for 2014 and the other years will result in higher net fixed assets on the balance sheet. Higher net fixed assets can further affect some of the ratios such as ROCE. This efficiency ratio utilises capital employed (net assets) and operating profit, both of which are affected by depreciation. A lower depreciation figure increases CE as the book value of assets is higher. Lower depreciation will also increase EBIT due to lower expense deductions. These effects can raise ROCE, which is often seen as a key or Primary Ratio in comparing the performance of potential of investments.

A higher depreciation rate chosen will create opposite consequences.

*Accept any other relevant consequence with an explanation.*

**N.B.** Candidates are not expected for **[3 marks]** to provide the exact detailed comments as above.

Candidates are not expected to refer to both higher and lower depreciation rates for the marks available.

Candidates are not expected to use figures to support their explanation of the effects of different depreciation rate.

Award **[1 mark]** for some implied but very limited knowledge of one consequence.

Award **[2 marks]** for one effect/consequence that is only described.

Award **[3 marks]** for one clear explanation of one possible consequence. For example, one effect on the balance sheet, or one effect on the profit and loss account.

- (d) **Examine the decision of *SF*'s Finance Manager to change the depreciation method from straight line to reducing balance.** [6 marks]

*SF*'s Finance Manager's decision to change the depreciation method from straight line to reducing balance will result in the following:

The manager will give up the advantages of the straight line method – it is simple and might be useful when the residual value is precisely known. The reducing balance method may also be more useful/realistic for *SF* as assets like scooters depreciate a lot/lose more value during the early years/months of usage. The value of the net fixed assets on the balance sheet will be more accurately reflected throughout.

Moreover, the repair and the maintenance costs for aging scooters are likely to increase as time goes by. Hence, if *SF*'s Finance Manager uses the reducing balance method, the total expenses on the profit and loss account will be more equal and accurate over time. As the depreciation amount decreases from \$32 000 in 2014 to \$6912 in 2017 the maintenance costs are highly likely to increase.

However, the Finance Manager is not sure of the depreciation percentage. 40% might be either too low or too high and hence the figures will be inaccurate.

The Finance Manager is also considering various legal ways of reducing *SF*'s tax liabilities / expenses in the coming year (2014). A high depreciation amount using the reducing balance method during the early years of the scooters under this method will enable the manager to show low net profit and hence low tax liability. The movement to the reducing balance method will also support the wishes of the family members who might be given more dividends if there are less tax liabilities. The above are relevant for the first two years.

*Accept any other relevant examination.*

**N.B.** It is **not** expected that candidates will include all of the above points in their answer.

A balanced response is one that covers at least **two** issues for and at least **two** issues against.

For one relevant issue that is one-sided, with no examination, award up to a maximum of [3 marks].

For one relevant issue that is balanced, with examination, award up to a maximum of [4 marks].

For more than one relevant issue that is one-sided, with no examination award up to a maximum of [4 marks].

Marks should be allocated according to the mark-bands on page 3.

2. (a) (i) **Define the term *outsourcing*.** **[2 marks]**

Outsourcing is the act of transferring internal business activities that are largely deemed peripheral to an external provider and provide some benefits to the organization like costs cutting.

Candidates are **not** expected to word their definition **exactly** as above. Examples are not expected.

*N.B.* Do not credit a definition of outsourcing.

Award **[1 mark]** for a basic definition that conveys partial knowledge and understanding.

Award **[2 marks]** for a full, clear definition that conveys knowledge and understanding similar to the answer above.

For **only** a relevant: example **or** application to the stimulus award **[1 mark]**.

(ii) **Identify *two* features of a quality control system.** **[2 marks]**

The features may include the following:

- quality is “controlled” by one person or department
- a percentage reject/wastage rate is accepted
- quality checks are made after production – it is retrospective
- if a fault is found then production is halted until the problem is resolved
- quality checks are per job and not for the whole process
- *accept any other relevant feature.*

*N.B.* Based on the assumption that quality control system is different to quality assurance/culture, a description of a feature of quality assurance is not relevant.

An identification of features is expected rather than a definition of what the system is.

Award **[1 mark]** for each appropriate feature identified up to a maximum of **[2 marks]**.

- (b) (i) Construct a fully labelled network diagram to represent the sequence of tasks in the table. Show the earliest starting time (EST) and the latest finishing time (LFT) for each task *and* identify the critical path. [6 marks]

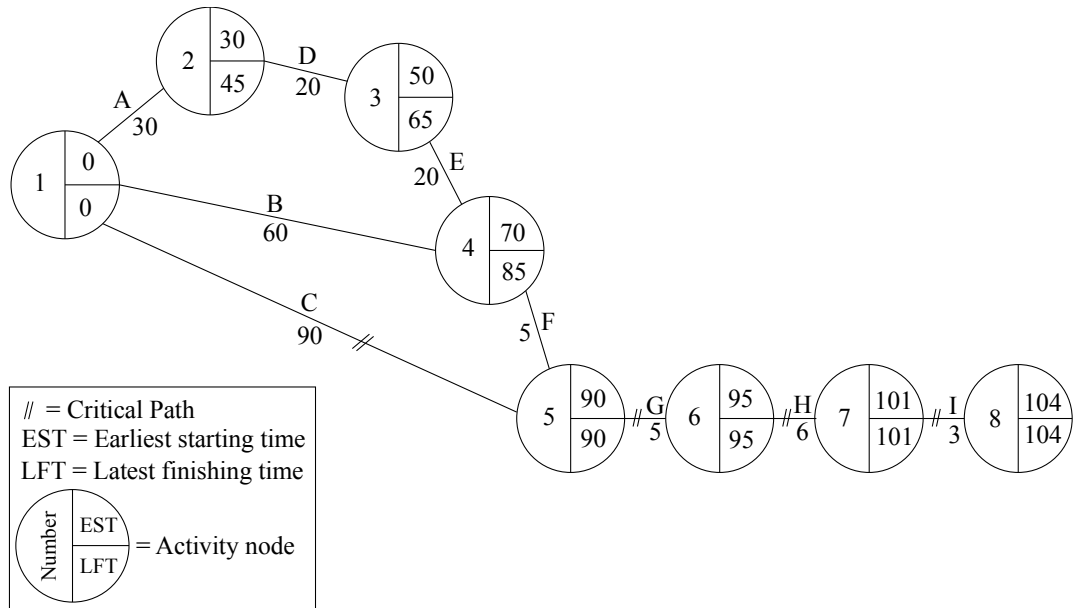

[1 to 3 marks]

There is some evidence of understanding of the model and some attempt at construction and ESTs and LFTs are shown.

[4 to 5 marks]

The network is constructed and drawn but may not be well and entirely accurately presented. The ESTs and LFTs are largely correct but there are up to two mistakes. The critical path may not be identified and a key may not be provided at the lower end of the band. If the network is well constructed but **either** the key **or** the critical path (one only) is not presented award [5 marks].

[6 marks]

The network is accurately constructed, drawn and well presented. The critical path is identified. A key is provided. The ESTs and LFTs are accurate.

Do not double penalize candidates.

- (ii) Calculate the total float and the free float for Task B and describe the impact of delaying Task B by 20 days. *[3 marks]*

$$\begin{aligned}\text{For Task B the total float} &= \text{LFT (task F)} - \text{Duration} - \text{EST (task B)} \\ &= 85 - 60 - 0 \\ &= 25 \text{ days}\end{aligned}$$

$$\begin{aligned}\text{For Task B the free float} &= \text{EST (task F)} - \text{Duration} - \text{EST (task B)} \\ &= 70 - 60 - 0 \\ &= 10 \text{ days}\end{aligned}$$

Therefore a delay of Task B by 20 days will delay Task F by 10 days but the whole production process is not delayed at all.

*N.B.* Apply Own Figure Rule (OFR) to calculations made in the previous question.

Award *[1 mark]* for the correct total float.

Award *[1 mark]* for the correct free float.

Award *[1 mark]* for the correct description of the impact of the delay.

If calculations are not shown, award up to *[2 marks]*.

- (c) Using a (cause-and-effect) fishbone diagram, explain why *Mapa* was slow to respond to the problem with its GPS devices. [6 marks]

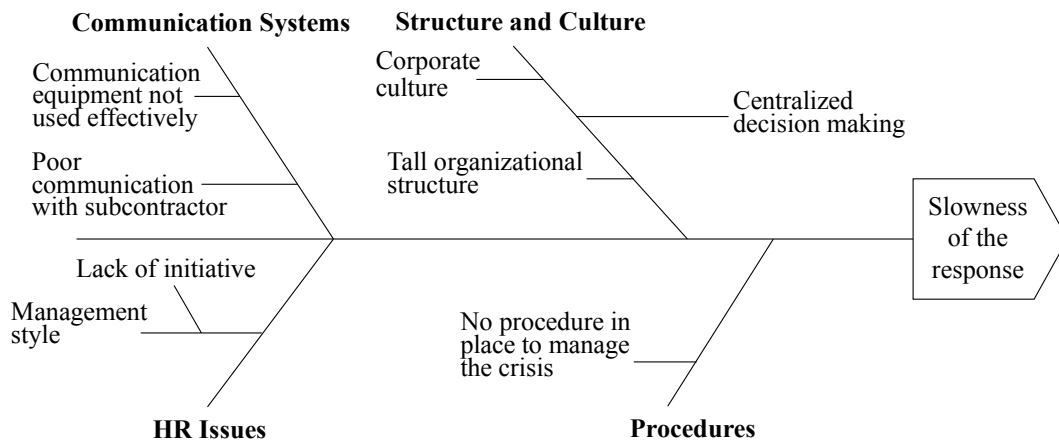

A fishbone diagram similar to above may be drawn. The cause of the problem can be any of those identified.

Explanation of how the issues identified caused the problem should follow.

**N.B.** The above headings are used as examples. Accept any other relevant headings (based on the information in the stimulus).

Award [1 to 2 marks] if the fishbone diagram is incomplete, or inaccurate and the description is limited.

Award [3 to 4 marks] if the fishbone diagram is incomplete, or does not include at least one applicable comment in each “bone”. The response may be descriptive or the explanation lacks depth.

Award [5 to 6 marks] if the fishbone diagram is complete (four bones) and includes at least one applicable comment in each “bone”. At least two issues are fully explained and are used effectively to explain the cause of the problem.

**N.B.** Award a maximum of [2 marks] for an explanation without the fishbone diagram.

Award a maximum of [2 marks] for fishbone diagram without any explanation.

- (d) **Examine the importance of communication for *Mapa* in its management of the crisis.** [6 marks]

**On one hand it can be argued that** a lack of communication was central to the creation of the problems / crisis and possibly also contributed to (mis)management of the crisis for the following reasons:

The poor external communication between *Mapa* and the Icelandic company due to language problems and different cultures created the poor quality of the GPS. It also weakened the ability of *Mapa* to respond to the crisis. However, *Mapa*'s slow response (internal) to the negative news reports escalated the crisis and caused a drop in confidence (external). Rumours, a form of unofficial communication channel, further undermined the credibility of *Mapa*'s GPS devices. Moreover, Poor internal communication hindered *Mapa*'s ability to respond to the crisis. Crisis management is all about being seen to respond swiftly and competently to an issue. *Mapa* clearly failed to do this.

On the other hand, the media picked up the news, which also acted as a catalyst for *Mapa* to respond and take action hence it can be argued that some forms of external communication channel and the message actually forced *Mapa* to handle the crisis.

Moreover, communication is not the only problem here. It could be argued that the root cause of the problem was the poor quality testing / control in Portugal in the summer that failed to pick up the defect. One can also argue that the tall structure and more importantly the bureaucratic corporate culture intensified the quality problems and made the management of the crisis less effective.

*Accept any other relevant examination.*

**N.B.** It is **not** expected that candidates will include all of the above points in their answer.

A balanced response is one that covers at least **two** issues for and at least **two** issues against.

For one relevant issue that is one-sided, with no examination, award up to a maximum of **[3 marks]**.

For one relevant issue that is balanced, with examination, award up to a maximum of **[4 marks]**.

Marks should be allocated according to the mark-bands on page 3.

**SECTION B**

3. (a) **Describe *two* possible influences on organizational culture.** **[4 marks]**

Two possible influences on organizational culture may include the following:

- the management style of the organization, the organization structure as well as the decision-making process, a tall structure and possible autocratic style will result in a different culture than a small, flat organization
- people behaviour, attitudes, the nature of the tasks that employees face, shared history, the owners' background, or personality
- the national culture may also influence an organizational structure
- *accept any other influence.*

*Accept any other relevant description.*

**Mark as 2 + 2.**

Award **[1 mark]** for each relevant and correct influence on organizational culture identified and **[1 mark]** for an appropriate description up to a maximum of **[2 marks]**.

- (b) (i) **Explain the importance of earnings per share to a shareholder.** **[2 marks]**

Earnings per share (EPS) is one of the shareholders ratios. It shows theoretically, the amount of dividends that a company could have paid to its shareholders if all of the net profit after interest and tax was paid in dividends and none was kept as retained profit. The higher the (EPS) figure the higher the dividends that could have been received per share.

Although it is unrealistic to expect such a management decision, it enables the shareholders to compare the actual dividends per share given with a potential sum. The ratio provides a useful indicator of the value of the company's shares.

*Accept any other relevant explanation.*

Award **[1 mark]** for identifying one issue of importance identified or for describing what the ratio **actually measures** and **[1 mark]** for an appropriate explanation of the importance of EPS up to a maximum of **[2 marks]**.

**N.B.** Do not credit candidates that just present the formula as it is given.

Do not credit candidates that refer only to the importance of profit and/or dividends. Candidates need to show understanding of the meaning of the ratio, especially as the ratio is given.



- (ii) **Distinguish between *two* external methods of recruitment that an organization could use to recruit a new CEO.** **[4 marks]**

Some of the external methods of recruitment that an organization could use to recruit a new CEO include:

- word of mouth – the owners might have heard of a successful person or a current CEO in a different organization and approach this person
- headhunting – possibly through a specialized agency that has a list of potentially suitable candidates
- advertising in national or global newspapers / magazines, internet, websites and so on
- *accept any other relevant external method of recruitment.*

Award **[1 mark]** for each relevant external method of recruitment identified and **[2 marks]** for an appropriate distinction between the two methods, up to a maximum of **[4 marks]**.

The suggested methods must be appropriate to the recruitment of a highly professional CEO. Do not credit candidates who just list some general methods that are not really appropriate such as job centres and local advertisements. Do not credit candidates that refer to internal recruitment.

(c) **Examine the usefulness to an organization of rapid change management imposed by a new “outsider” CEO.** [6 marks]

Rapid change management imposed on an organization by a new “outsider” CEO can be necessary and hence useful for the following reasons:

During crisis, financial or otherwise, rapid action and decision making is needed. It is often better for a CEO with (possibly) other senior managers to react quickly to make an imposed strategic or tactical decision. A slow, negotiated change management strategy will delay the process of change. Some dire consequences to an organization may occur in the meantime. The newly appointed CEO is likely to have the right industry knowledge, the confidence, shareholders’ support and experience to pursue the change.

An imposed and rapid change may also be suitable when the employees are not ready yet in terms of skills and experiences and/or unwilling to get involved in strategic change. Some argue that change management in this situation is better left to the CEO with his/her experience/skills. A short process that leads to a rapid change is less costly.

The structure, culture and nature of the organization (military, dangerous product, confidential information, nuclear reactor) also affect the nature of change management.

However, a rapid and imposed change is likely to create resentment and resistance if the employees do not perceive the situation as some sort of crisis and/or if they believe that they have the skills, experience and willingness to be consulted and believe they should be allowed to participate in the change management process.

As stated in the stimulus, the new “outsider” CEO may be over confident regarding the support he/she might have as well as inside knowledge and experience. Not being familiar with the culture of an organization especially if the employees are willing and able to participate in the required change management could lead to industrial unrest / dispute / de-motivation and even the loss of skilled employees. Moreover, rapid change will not allow time for training and development, communication and so on.

A non negotiated/imposed change can create fear and seriously affect the motivation of the employees who may feel unappreciated or unimportant. A slow change and possibly a negotiated one is likely to be more accepted and more easily implemented. For these reasons it can be argued that negotiated and possibly incremental change management should be more useful.

*Accept any other relevant examination.*

It is **not** expected that candidates will include all of the above points in their answer.

A balanced response is one that covers at least **two** issues for and at least **two** issues against.

For one relevant issue that is one-sided, with no examination, award up to a maximum of [3 marks]. For one relevant issue that is balanced, with examination, award up to a maximum of [4 marks].

Marks should be allocated according to the markbands on page 3.

- (d) Discuss whether organizations that promote CEOs internally are more likely to be successful.** [9 marks]

By promoting internally there is a cost cutting advantage and the potential to create competitiveness. This, however, is likely to be offset by the 65% higher financial rewards and the shorter length in service. Also, recruiting a new CEO is a very expensive and time consuming process. Having to recruit a new CEO relatively frequently may erode the cost cutting merit.

The research presented in the table indeed found that those companies who routinely promoted CEOs from within (internally) significantly outperformed those that were recruited externally. However, there are some issues regarding the validity of the research:

- these findings are not the most up to date (ends 2007). Perhaps more up to date information should have been consulted.
- only certain types of organizations were researched – 36 large public limited companies. Perhaps different types of organizations require different types of CEOs, possibly “outsiders” with fresh ideas and those who are not possibly constricted by the current organizational culture.
- also, the research has been done on American companies. In different parts of the world with different national and organizational culture the results may have been different – in favour of “outsiders”.
- the sample size of 36 might not be fully representative.
- *accept any other arguments in terms of possible limitations of the market research.*

Candidates may also refer to some motivational theory.

Content motivation theories like Maslow and Herzberg, and process theories like Adams identify the benefits of promoting from within to such a desirable position of CEOs. The motivation of the promoted person as well as that of his/her peers can significantly improve the chance of promotion, the availability of a very challenging job can be seen as a “motivator” according to Herzberg as well as a chance for the employees to achieve self esteem / self actualization needs according to Maslow. A valued outcome and sense of fairness may also increase motivation. (It is not expected that a long discussion is presented about the motivation theories.)

Nevertheless, given the fact that only one person is likely to be promoted within a period of time, this might somewhat reduce the significance of the above arguments.

However, it can be argued that rapid and drastic change if needed in emergency situations may require a competent CEO who feels he/she got the mandate to impose the change. It states in the stimulus that “outsiders” feel more empowered to implement changes. Outsiders may also be better at crisis management with fresh ideas / strategy and the power/mandate to implement them.

On the other hand, employees might be more willing to follow change if carried out / led by a person who knows and understands the organization. Less resistance to change is likely to occur.

However, those who were not promoted might feel resentment and become demotivated (the opposite use of the different motivation theories as above) and might actively resist changes.

The culture may be negatively affected and the organizations' accumulated knowledge / know-how could be lost especially if other senior managers leave.

The financial performance indicators are significantly higher in companies led by "insiders".

Overall, based on the information given in the stimulus, one may conclude that the benefits of using "insiders" are greater than the arguments against. The figures and the examples of successful companies (well known worldwide) clearly support that notion. Nevertheless, one has to be aware of a possible bias and the concentration of the research on 36 large public limited American companies.

**N.B** Given question (c) the issue of change management is of less significance in this response.

*It is not expected that all the points/issues above are covered.*

*Accept any other relevant arguments for or against promoting internally.*

*Accept any other substantiated conclusion/judgment.*

It is not expected that the answer includes specific motivation theories or theorists for the candidates to reach the top markband.

A balanced response is one that covers at least **two** arguments in favour and at least **two** arguments against.

For one relevant issue that is one-sided, award up to **[3 marks]**. If the response is a one-sided relevant approach with no analysis/examination award a maximum of **[4 marks]**.

Award a maximum of **[5 marks]** if the answer is of a standard that shows balanced analysis and understanding throughout the response with reference to the stimulus material **but** there is no judgment/conclusion.

Candidates cannot reach the **[5–7]** markband if they give judgment/conclusions that are not based on analysis/explanation already given in their answer.

Marks should be allocated according to the markbands on page 4.

4. (a) Describe *one* advantage and *one* disadvantage to an organization of using e-commerce. **[4 marks]**

Some of the advantages may include the following:

- an organization can reach a wider customer base
- low set up cost – money can be saved on rent and sales assistants if only e-commerce is used
- alternatively, if e-commerce is to be added to an already functioning organization, the cost of buying the technology is usually not very high
- transaction costs are relatively low.

Some of the arguments against:

- security issues – credit/debit card numbers may be stolen; personal information may be taken by hackers
- some people do not feel confident in using electronic devices when shopping
- some customers are put off by the intangibility of the process and hence reduce their demand.

*Accept any other relevant advantage or disadvantage with a description, provided it refers to the seller not to the customer.*

**Mark as 2 + 2.**

Award **[1 mark]** for each relevant advantage/disadvantage identified and **[1 mark]** for an appropriate description up to a maximum of **[2 marks]**.

- (b) (i) Explain *one* benefit of sales forecasting for an organization. **[2 marks]**

Sales forecasting uses past and current data which can be seen as a useful planning tool to reduce future uncertainties. Researchers identify the trend based on a method of moving average to forecast the sales figures in the future. Sales forecasting enables various budgets to be prepared for different functions in the organization and objectives and strategies to be set at various levels.

*Accept any other relevant explanation.*

Award **[1 mark]** for a relevant benefit identified and **[1 mark]** for an appropriate explanation up to a maximum of **[2 marks]**.

- (ii) **Distinguish between seasonal *and* cyclical variations to predict sales trends.** **[4 marks]**

**Seasonal variations** are used to adjust the predicted sales from the trend within one year to make a more accurate prediction for a specific quarter (season). The forecaster adjusts the predicted seasonal trend by the average fluctuation in the previous season.

Over time, **cyclical fluctuations** occur in the sales figures due to the variation in the business / economic cycles. The changes are the result of recessions and booms in the economic cycle. To make the forecasted figures from the trend more accurate, a forecaster adjusts the predicted sales figures by the average of the cyclical variations.

**[1 to 2 marks]**

Award **[1 mark]** for an answer that shows some basic knowledge of the concepts *eg* brief definitions of seasonal and cyclical variations. Award **[2 marks]** for a theoretical answer that shows some clear, basic knowledge of the difference between seasonal and cyclical variations.

**[3 to 4 marks]**

For **[3 marks]** the candidate links either seasonal or cyclical variations to sales trends. For **[4 marks]** there is distinction between seasonal and cyclical variations and how they are used to **adjust** the originally predicted/forecasted sales which was based on the trends.

- (c) **Examine the usefulness of traditional secondary research to identify market trends and for forecasting.** **[6 marks]**

The traditional method of collecting past secondary data and to make forecasts can be seen as useful/relevant/reliable tool when the market is stable or slow changing and when the forecast is done for a very short period. Moreover, the traditional method of collecting secondary sources and forecasting could also be seen as reliable if the sources are known as reliable and unbiased. Collecting data that already exists can save time and effort for the researchers.

However, the main assumption that what happened in the past will likely happen in the future is overly simplistic and often inaccurate, given the fast moving and often unstable both internal and external environment. The figures used may be outdated and to some extent also unreliable – it depends on who collected the figures; and how. Long-term forecasts from the trend are likely to be less reliable.

*Accept any other relevant points for and/or against.*

*Accept any other relevant examination.*

**N.B.** Candidates may emphasize more the issue of forecasting, or the issue of secondary sources, give credit for both.

If the response does not address the issue of forecasting award up to **[4 marks]**.

For a text book response that covers the advantages and/or disadvantages of secondary research as oppose to primary research, award **[2 marks]**.

It is **not** expected that candidates will include all of the above points in their answer.

A balanced response is one that covers at least **two** issues for and at least **two** issues against.

For one relevant issue that is one-sided, with no examination, award up to a maximum of **[3 marks]**.

For one relevant issue that is balanced, with examination, award up to a maximum of **[4 marks]**.

Marks should be allocated according to the mark-bands on page 3.

- (d) Evaluate the use of “social media to collect online messages in order to understand consumers’ moods” for making market predictions. [9 marks]**

One may argue that the use of social media to discover consumers’ moods and to make market predictions is the most up to date advanced way to do so. It gives real-time information rather than relying on the use of old data.

More people are now using the various types of social media, so the size of the market is big enough for meaningful results. The statistics clearly demonstrate a significant growth of users.

Many customers are unfazed by researchers and moreover, are willing to constantly share information and opinions with anybody who might be interested.

The technological advancement also makes the process more accurate and definitely cheaper and quicker.

Increasingly, better known companies use social media to communicate with their current and potential customers. The use of social media for market research can be seen as a natural progression. Many customers are very willing to share their opinion, thoughts, habits, *etc.*

*Accept any other relevant issue.*

However, Mr Watts, an Internet researcher at *Yahoo!* said that “to be useful, a forecasting technique must add something new to what is already known. The use of social media will only add value to forecasting if other sources of information are limited”. Researchers might just get some obvious information that is open for all to see.

Sophisticated methods based on natural language analysis of tweets, blogs or *Facebook* pages currently use / hold “disruptive potential”. Information might be gathered only from the people who are more technologically savvy, or are more open to share information at all times. Some possible misleading information or

at least unrepresentative information might be gathered. See the statistics of the user of *Twitter*. The information gathered might enable various companies to target Caucasians well who are young. Other age groups and other ethnic groups might be ignored or not well served. While it might be useful for some organizations, it might not be useful for others like those who want to research the older segments of the population, or mainly non-Caucasian groups. Also, some issue of censorship in some countries may still exist.

*Accept any other relevant argument.*

On balance / in conclusion:

Given the fact that more and more people and commercial companies use some sort of social media, it looks as if such research can be very useful for some organizations. For others, it is clearly not. Researchers need to be aware of the targeted sample and the fact that others might also have the same information and may possibly deliberately misinform. Provided that the market research is not solely carried out through the use of social media, one might conclude that the use of social media for market research and further predictions can be judged as useful and efficient provided that the researchers are aware of the limitations and use other methods as well. Moreover, the availability of technology that can recognize sarcasm, cultural differences and so on is a major positive argument in favour of the use or possibly the growing use of social media.

*Accept any other substantiated judgment.*

A balanced response is one that covers at least **two** arguments in favour and at least **two** arguments against.

For one relevant issue that is one-sided, award up to **[3 marks]**. If the response is a one-sided relevant approach with no analysis/examination award a maximum of **[4 marks]**.

Award a maximum of **[5 marks]** if the answer is of a standard that shows balanced analysis and understanding throughout the response with reference to the stimulus material **but** there is no judgment/conclusion.

Candidates cannot reach the **[5–7]** markband if they give judgment/conclusions that are not based on analysis/explanation already given in their answer.

Marks should be allocated according to the markbands on page 4.



5. (a) **Define the term *patent*.** **[2 marks]**

A patent is the exclusive right, granted by a government, to make use of an invention or process for a specific period of time. It gives the inventor the intellectual property rights to the invention.

Candidates are **not** expected to word their definition **exactly** as above.

Award **[1 mark]** for a basic definition that conveys partial knowledge and understanding.

Award **[2 marks]** for a full, clear definition that conveys knowledge and understanding similar to the answer above.

For **only** a relevant: example **or** application to the stimulus award **[1 mark]**.

(b) **Describe *one* problem faced by a new business start-up.** **[2 marks]**

The problems may include finding the following:

- the funds
- the lack of the product differentiation / USP
- difficulties in recruiting suitable and experienced employees
- the lack of an established relationship with suppliers
- the costly and time-consuming legal aspects
- a lack of experience in strategic decision making
- *accept any other relevant problem.*

*Accept any other relevant description.*

Award **[1 mark]** for a relevant problem identified and **[1 mark]** for a full, clear description that conveys knowledge and understanding, up to a maximum of **[2 marks]**.

- (c) **Explain the role and importance of research and development (R&D) for Kodak.** [6 marks]

The **role** of R&D is to conduct extensive research into features, designs, testing of prototypes and so on in order to develop a new / unique, innovative product. By doing so:

- More value being added over and above the cost of resources – R&D plays an important role in lowering the costs of resources or their processing
- Rapid and successful R&D provided a competitive advantage to *Kodak* in the film processing business. *Kodak* enjoyed, and could have enjoyed with subsequent products, a first mover advantage by product differentiation. Its R&D did result in new products, as stated in the stimulus, digital cameras, photo viewing and photo sharing products, R&D was very important for *Kodak* earlier on.
- R&D can improve brand perception (as an innovator) and acts as a barrier to entry for other competitors.

The above can result in an improved new and large product range, greater appeal to a broader range of market segments and better performance in terms of lower costs, higher revenue.

*Kodak* understood the role and the importance of R&D. The above should have led to a long- (as well as short-) term success. *Kodak* dominated the film processing industry for a long while.

*Accept any other relevant explanation.*

**N.B.** A clear distinction between the role and importance is not expected.

Award [1 to 2 marks] if the response is limited and descriptive. There is no or limited reference to the stimulus material (name only) and the response is mainly theoretical.

Award [3 to 4 marks] if the explanation lacks some depth and less than two issues are covered. The candidate has referred directly to the stimulus material. A response that is based on the issue of market research without covering the issue of development, award up to [3 marks].

Award [5 to 6 marks] if the explanation is detailed **and** covers at least two issues. The candidate has referred directly to the stimulus material. For [6 marks] a clear distinction between research and development should have been made.

(d) Using the Boston consulting group (BCG) matrix, examine the reasons for *Kodak's* bankruptcy. [6 marks]

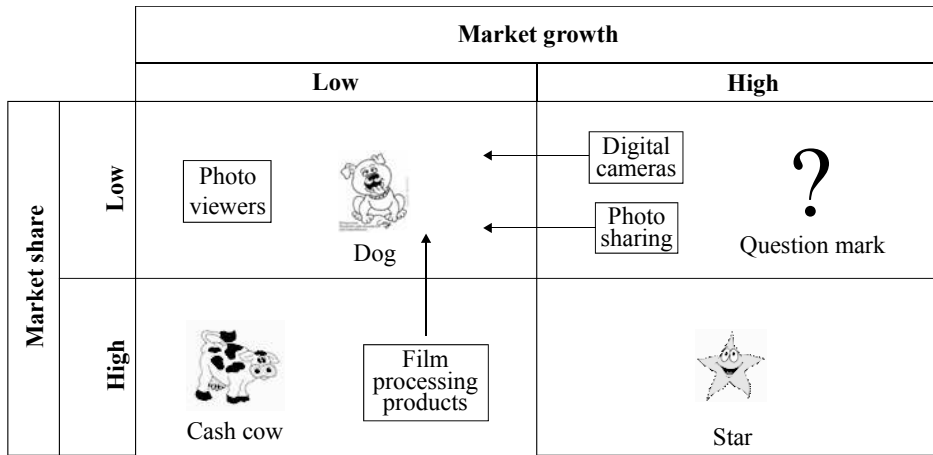

The BCG matrix may look like the one above.

On one hand, the **film processing cameras** were clearly different from the others. These products went through the full product life cycle, became cash cows and eventually, went into decline and became dogs. It is stated in the stimulus that *Kodak* had long dominated the market. *Kodak* quite likely used/milked the cash from these products to develop and promote the other products mentioned in the stimulus. It appeared that the **film processing cameras had a long maturity and saturation stages eventually** moved from being a cash cow to becoming a dog so one may argue that the issue of developing, introducing and managing new products was not a contributor to the bankruptcy.

On the other hand, the **photo viewer market** was the wrong market for *Kodak* as the market had low growth and they were not the leader; clearly the *Kodak* photo viewers became dogs soon after being a question mark. Hence the management of this product can be seen as a contributor to the bankruptcy.

Moreover, the **digital and photo sharing cameras** had potential that was realized to a small extent only / never realized. For the **digital cameras**, *Kodak* did not sufficiently develop the technology. *Kodak* also failed to patent some of its innovation (photo sharing). Better innovation by other firms pushed these products to the dog position very rapidly.

While *Kodak* did attempt to develop various new products – a process that was very expensive given the technological and competitive nature of the market – and introduced these products into the market, it appears that *Kodak* managers did not manage to keep a balanced portfolio of products. Not enough revenue and profit was generated when the cash cow started to become a dog. Hence, despite innovation and product development, the type of the new products as well as the management of the profile can be seen as the reason for *Kodak's* bankruptcy.

**N.B.** The candidate may draw a different BCG matrix where the market share and the market growth axis are reversed. It is expected that the BCG matrix shows some movement of the products. It is not sufficient to only place all the products in the dog quadrant without an explanation of how they might have arrived there.

**N.B.** If the candidate does not make use the BCG matrix either by drawing or describing then they can only achieve a maximum of **[2 marks]**.

Award **[1 to 2 marks]** if the response is limited and descriptive and covers less than **three** products and the answer does not look at the movement of the products. Award **[0 marks]** if the matrix only is presented. Award up to **[2 marks]** if the matrix only is accurately drawn and there is an attempt to place some of the product.

Award **[3 to 4 marks]** if the examination is limited and lacks some balance but covers **either** less than the **four** products **or** the answer does not look at the movement of the products. For one relevant issue that is one-sided, with no examination, award up to a maximum of **[3 marks]**. For one relevant issue that is balanced, with examination, award up to a maximum of **[4 marks]**. For a balanced and accurate examination without drawing the BCG matrix, award up to **[4 marks]**.

Award **[5 to 6 marks]** if the examination is detailed and balanced by covering some positive comments on *Kodak's* product portfolio. The answer covers all **four** products. The answer looks at the movement of the products. A balanced response is one that covers at least **two** issues for and at least **two** issues against.

- (e) **With reference to *Kodak* and one other organization of your choice, evaluate the merits of small versus large organizations.** **[9 marks]**

It appears that *Kodak* as a relatively large organization has sufficient finance for R&D as *Kodak* introduced a number of new products throughout the years. Therefore, greater product range can be seen as an advantage of a large organization. The risk of relying on one or very few market segments is much reduced. Large organizations can benefit from global brand recognition as *Kodak* did and enjoy different types of economies of scale; purchasing, marketing, managerial and so on. However, it may be argued that *Kodak* was overly confident perhaps due to its size and its success with the film processing business and did not pay attention to other competitors' new product and marketing strategies until it eventually went bankrupt.

Perhaps being a large organization did not enable *Kodak* to operate in a niche market like small competitors might do. Small organizations can channel their more limited resources to satisfy the needs of a niche market or a small segment and become extremely customer focused. Customers' needs are likely to be satisfied with perhaps more personalized service and close contact. Perhaps *Kodak* as a large organization was not aware of the changing needs of the customers.

*Kodak* lacked the flexibility like a small organization to respond to the changing need of customers and to become innovative like some small startup companies did with their innovative products.

A small start-up company may be more reluctant to take risks with its product as it has to create a USP and compete against large companies like *Kodak*. The increasing number of start-ups especially in this highly technological industry is evident.

Conclusions/judgment:

It is not expected that a definite verdict is given. It is evident that even larger organization like Apple performed very well, however, there are some current issues with innovation. Many start-up companies become successful after being small but many aim to grow – *Facebook, Twitter, Google*.

There is no explicit evidence that *Kodak* failed due to its size. The conclusions in the last part of the stimulus do not refer to size but to strategic vision, to the failure due to new products that were taken off the market too quickly, a failure to patent innovation and being afraid of cannibalism. Perhaps size does not matter but management vision/ attitude to risk and so on does.

*Accept any other relevant point for or against a large organization. These points may be theoretical.*

*Accept any relevant evaluation incorporating any benefits such as those above.*

**N.B.** Flexibility in marking is very important in this case given the different nature of the question. Expect more reference to *Kodak* rather than specific application to another organization.

Do not penalize if a specific name of a small organization is not given. Expect some comparison between large and small organizations.

A balanced response is one that covers at least **two** arguments in favour and at least **two** arguments against.

For one relevant issue that is one-sided, award up to **[3 marks]**. If the response is a one-sided relevant approach with no analysis/evaluation award a maximum of **[4 marks]**.

Award a maximum of **[5 marks]** if the answer is of a standard that shows balanced analysis and understanding throughout the response with reference to the stimulus material **but** there is no judgment/conclusion.

Candidates cannot reach the **[5–7]** markband if they give judgment/conclusions that are not based on analysis/explanation already given in their answer.

Marks should be allocated according to the markbands on page 4.